

DESCRIPTION	REVISIONS	DATE

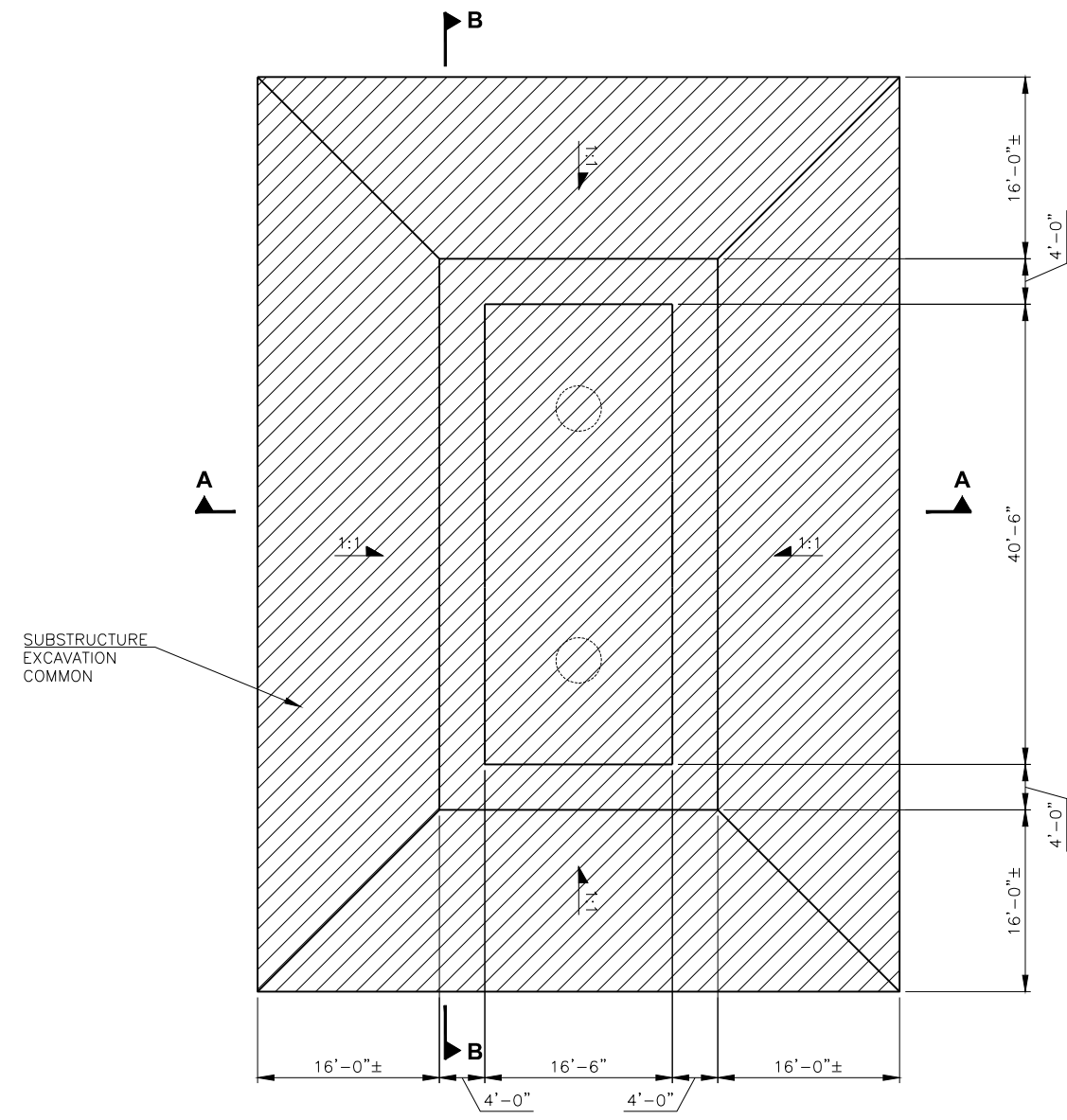

SUBSTRUCTURE EXCAVATION COMMON

NOTE:
FOR SUBSTRUCTURE EXCAVATION AT ABUTMENTS AND PIPE UNDERDRAIN DETAILS, SEE STD. B40-C-ABUT-MISC.

NOTE:
THE CONTRACTOR WILL INCLUDE ALL COST OF TEMPORARY RETAINING STRUCTURES AND TEMPORARY WATER CONTROL SYSTEMS NECESSARY TO CONSTRUCT THE BRIDGE PIERS, INCLUDING EQUIPMENT, MATERIALS, LABOR, AND INCIDENTALS, IN THE CONTRACT UNIT PRICE BID FOR "SUBSTRUCTURE EXCAVATION COMMON". ANY TEMPORARY RETAINING STRUCTURES AND TEMPORARY WATER CONTROL SYSTEMS WILL BE PROVIDED IN ACCORDANCE WITH SECTION 502 OF THE SPECIFICATIONS.

SUBSTRUCTURE EXCAVATION PLAN

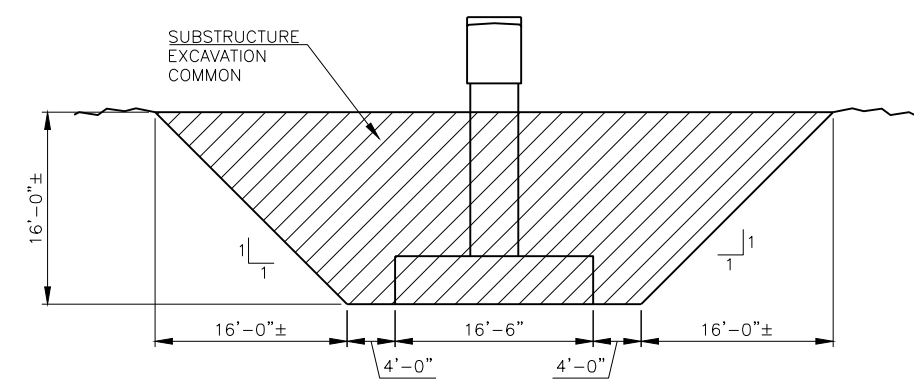

SECTION A-A

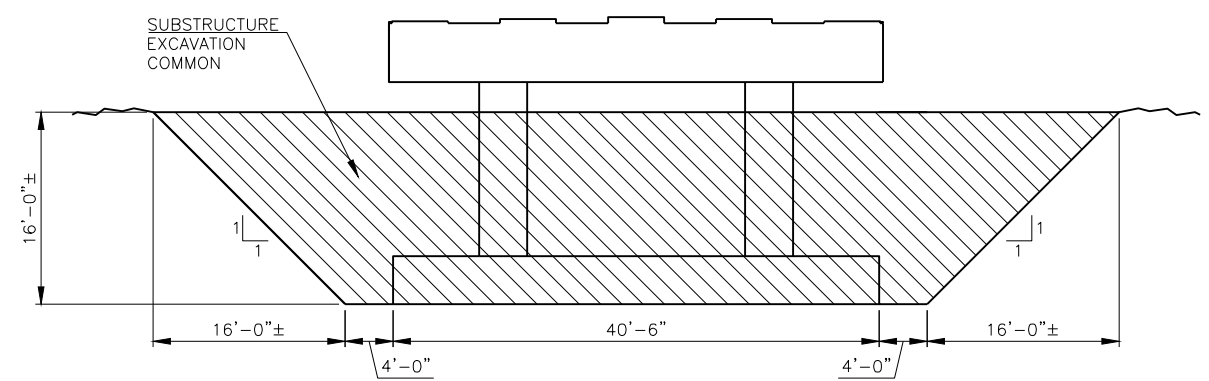

SECTION B-B

THIS DRAWING IS PRELIMINARY IN NATURE. IT IS NOT A FINAL SIGNED AND SEALED DRAWING

DESIGN	J.W.H.
DRAWN	R.A.P.
CHECKED	J.W.H.
APPROV.	T.A.C.
SQUAD	CEC

SH34 OVER N. PERSIMMON CREEK WOODWARD COUNTY BRIDGE A

SUBSTRUCTURE EXCAVATION AT PIERS